

MX Series

Counterbalanced Forklift Trucks

4,000 / 5,000 / 6,000 lbs.

- Perfect combination of power, speed and low fuel consumption
- Extensive option offering for a variety of cost-effective configurations
- Engineered for advanced dependability, productivity and easy serviceability
- Operator compartment ergonomically designed for ultimate comfort



Truck Dimensions

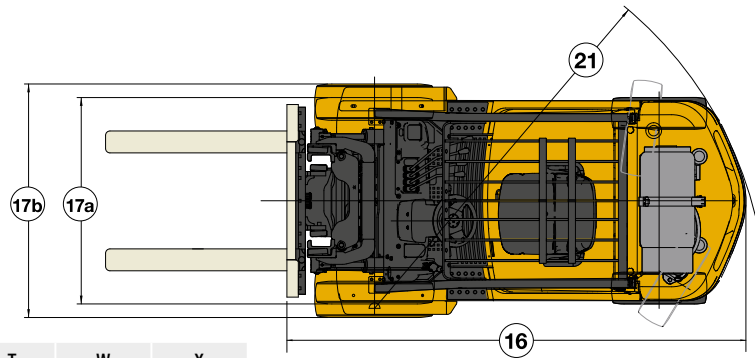

Truck model	C	D	E	T	W	X
	in (mm)	percent	percent	in (mm)	in (mm)	in (mm)
GP040MX	17.1 (434)	70	53	6.6 (168)	13.7 (349)	27.6 (702)
GP050MX	19.5 (495)	55	53	6.6 (168)	13.7 (349)	27.6 (702)
GP060MX	20.4 (518)	58	58	7.4 (168)	14.5 (369)	28.4 (722)

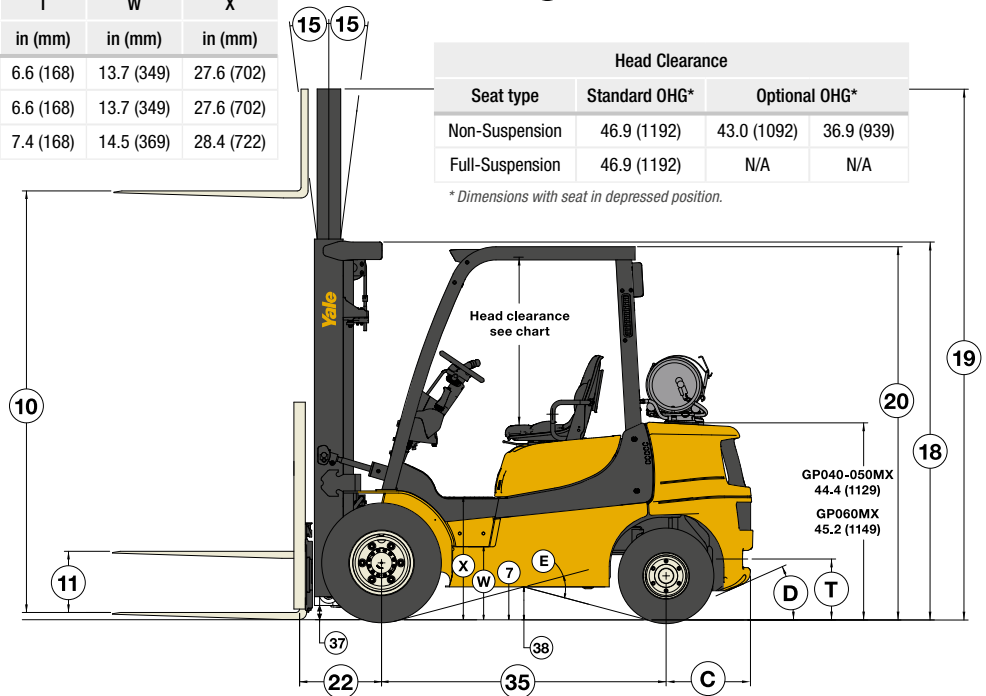

Head Clearance			
Seat type	Standard OHG*	Optional OHG*	
Non-Suspension	46.9 (1192)	43.0 (1092)	36.9 (939)
Full-Suspension	46.9 (1192)	N/A	N/A

* Dimensions with seat in depressed position.

GP040-050MX Mast Dimensions

Maximum Fork Height (TOF) †	Overall Lowered Height	Overall Extended Height		Free-Lift (TOF)		Approximate Total Weight of Standard Equipped Truck	
		w/Load Backrest	w/o Load Backrest	w/Load Backrest	w/o Load Backrest	GP040XM	GP050XM
in (mm)	in (mm)	in (mm)	in (mm)	in (mm)	in (mm)		
2-Stage Limited Free-Lift (LFL) Hi-Vis™ 2 Mast							
129 (3290)	86 (2170)	178 (4515)	154 (3904)	5 (140)	5 (140)	7990 (3624)	8720 (3955)
3-Stage Full Free-Lift (FFL) Hi-Vis™ 2 Mast							
171 (4350)	78 (1970)	220 (5570)	195 (4935)	29 (750)	54 (1390)	8270 (3751)	9000 (4082)
189 (4800)	84 (2120)	237 (6020)	213 (5385)	35 (900)	60 (1540)	8340 (3751)	9080 (4119)
194 (4950)	86 (2170)	243 (6170)	218 (5535)	37 (950)	62 (1590)	8370 (3797)	9110 (4132)
200 (5100)	90 (2270)	249 (6320)	224 (5685)	41 (1050)	66 (1690)	8410 (3815)	9150 (4150)
218 (5550)	96 (2420)	267 (6770)	242 (6135)	47 (1200)	72 (1840)	8500 (3856)	9240 (4191)

GP060MX Mast Dimensions

Maximum Fork Height (TOF) †	Overall Lowered Height	Overall Extended Height		Free-Lift (TOF)		Approximate Total Weight of Standard Equipped Truck	
		w/Load Backrest	w/o Load Backrest	w/Load Backrest	w/o Load Backrest	GP060MX	
in (mm)	in (mm)	in (mm)	in (mm)	in (mm)	in (mm)		
2-Stage Limited Free-Lift (LFL) Hi-Vis™ 2 Mast							
126 (3209)	89 (2245)	175 (4430)	154 (3905)	5 (150)	5 (150)	10050 (4559)	
3-Stage Full Free-Lift (FFL) Hi-Vis™ 2 Mast							
181 (4615)	87 (2195)	230 (5840)	208 (5260)	37 (965)	63 (1600)	10410 (4722)	
187 (4768)	91 (2295)	236 (5990)	213 (5410)	41 (1065)	65 (1655)	10460 (4745)	
211 (5368)	101 (2545)	260 (6590)	237 (6010)	51 (1315)	75 (1905)	10590 (4804)	
228 (5815)	107 (2695)	278 (7040)	256 (6495)	57 (1465)	80 (2055)	10770 (4885)	

† lift heights over 171" (4356 mm) maximum fork height are considered highlifts and require reduced capacity and restricted back tilt.

Total approximate weights listed include mast, standard carriage, load backrest extension, pneumatic tires and 70 lbs. tank and tank bracket.

General Specifications GP040-060MX - LPG, Dual Fuel

				Yale®					
GENERAL	1	Manufacturer							
	2	Model designation		GP040MX	GP050MX	GP060MX			
		Engine		PSI 2.4L					
	3	Rated capacity	lbs (kg)	4,000 (1814)	5,000 (2,268)	6,000 (2722)			
	4	Load center	in (mm)	24 (610)					
	5	Drive power type: LPG, Dual Fuel		LPG	Dual Fuel	LPG	Dual Fuel	LPG	Dual Fuel
	6	Operation		Sit-down rider					
	7	Step height	in (mm)	16.3 (415)			17.1 (435)		
	8	Tire type - Cushion, Solid, Pneumatic		Pneumatic					
9	Number of wheels, front/rear (X = driven)		2X/2						
DIMENSIONS	10	Lift height, top of fork (TOF)	in (mm)	129 (3292)			126 (3209)		
	11	Lift heights, standard limited free lift (LFR) wLBR (TOF)	in (mm)	5 (140)					
		Lift heights, optional full free lift (LFR) wLBR (TOF)	in (mm)	58 (1490)					
	12	Standard carriage width	in (mm)	42 (1067)					
	13	Fork dimensions	in (mm)	1.6 X 3.9 X 42 (40 X 100 X 1067)					
	15	Mast tilt, forward / back	degrees	6 / 6					
	16	Length to face of forks	in (mm)	99.5 (2528)	101.9 (2589)	106.3 (2701)			
	17a	Overall width (standard tread)	in (mm)	45.7 (1162)			46.9 (1191)		
	17b	Overall width (wide tread)	in (mm)	52 (1322)			52.2 (1326)		
	18	Height, standard mast - lowered	in (mm)	86 (2170)			89 (2245)		
	19	Height, standard mast - extended with LBR	in (mm)	147 (3715)			175 (4330)		
		Height, standard mast - extended without LBR	in (mm)	123 (3100)			154 (3905)		
	20	Height, standard overhead guard	in (mm)	87.7 (2228)			88.2 (2241)		
		Height, optional overhead guard	in (mm)	83.8 (2128)			84.3 (2140)		
	21	Turning radius, minimum outside (OTR)	in (mm)	85.7 (2178)	88 (2236)	91.5 (2324)			
	22	Length, center of wheel to face of forks	in (mm)	18.5 (471)			19 (483)		
	23	Aisle width, right angle stack (add length of load)	in (mm)	104.3 (2649)	106.6 (2707)	110.3 (2802)			
	24	Equal aisle, 90° intersecting aisle	in (mm)	79.9 (2030)	80.9 (2056)	83 (2108)			
	PERFORMANCE	25	Travel speed, powershift transmission RL/NL	mph (km/hr)	11.4/11.6 (18.4/18.6)			12.3/12.4 (19.8/20)	
		26	Lifting speed, standard 2-stage LFL RL/NL	ft/min (m/sec)	128/134 (0.65/0.68)			112/118 (0.57/0.60)	
			Lifting speed, optional 3-stage FFL RL/NL	ft/min (m/sec)	120/126 (0.61/0.64)				
		27	Lowering speed, standard 2-stage LFL RL/NL	ft/min (m/sec)	114/98 (0.58/0.50)				
			Lowering speed, optional 3-stage FFL RL/NL	ft/min (m/sec)	114/98 (0.58/0.50)				
		28	Drawbar pull @ maximum RL/NL	lbs (kg)	4947/2282 (2244/1035)	4916/2217 (2230/1006)	4438/2534 (2013/1149)		
		Drawbar pull, standard transmission @ 1 mph RL/NL	lbs (kg)	4186/2282 (1899/1035)	4154/2217 (1884/1006)	3792/2534 (1720/1149)			
29		Gradeability, standard transmission @ 1 mph RL/NL	%	35.9/31.5	30.2/27.6	23.5/27.6			
WT.		31	Weight, standard truck (2-stg. LFL 84/127) NL	lbs (kg)	8170 (3705)	8910 (4040)	10300 (4671)		
		Weight, standard truck (2-stg. LFL 84/127) RL	lbs (kg)	12170 (5520)	13910 (6308)	16300 (7392)			
	32	Axle loading, static front/rear NL	lbs (kg)	3855/4311 (1748/1955)	3695/5210 (1676/2363)	4207/6089 (1908/2761)			
		Axle loading, static front/rear RL	lbs (kg)	10518/1648 (4770/747)	12024/1881 (5453/853)	14064/2232 (6378/1012)			
WHEELS & TIRES	33	Tire size - front		7.00 x 12 - 12			28 x 9 - 15		
	34	Tire size - rear		6.00 x 9			6.50 x 10		
	35	Wheelbase		63.9 (1623)			66.9 (1700)		
	37	Ground clearance		3.3 (84)			4.1 (104)		
	38	Ground clearance at center of wheelbase		7.5 (190)			8.3 (210)		
	39	Service brake - method of control/operation		Hydraulic/Foot					
	40	Parking brake - method of control/operation		Mechanical/Hand					
TRANS. & POWER UNIT	41	Battery type		Maintenance Free					
	42	Battery volts/cold cranking amps		12V / 475					
	43	Engine manufacturer/type		PSI 2.4L					
	44	Permanent output	hp (kw)	62 (46)					
	45	Torque @ rated RPM	ft. lbs (kg-m)	124 (17.1)					
	46	Number of cylinders/displacement	No./cc (ci)	4/2351 (143)					
	47	Transmission type, standard		Electronic Powershift					
		Standard speeds, forward - reverse		1-1					
	49	Hydraulic tank capacity (drain and refill)	gal (liters)	11.1 (42)					
	50	Fuel tank capacity (gas powered units only)	gal (liters)	18.2 (69)					
	51	Auxiliary hydraulic pressure relief for attachments	PSI (Mpa)	2550 (17.6)					

RL = Rated Load, NL = No Load

MX series

Models: GP040MX, GP050MX, GP060MX

Standard equipment	Options
<ul style="list-style-type: none">• PSI 2.4L LPG engine• Electronic powershift transmission• Column mounted shift lever• 2-stage LFL Hi-Vis™2 mast• 42" wide hook-type carriage with 48" tall load backrest• 42" forks• 6 forward/6 back tilt• 3-function hydraulic control valve• Integrated dashboard display• Hydrostatic power steering• Non-suspension vinyl seat with non-cinch seat belt• Electronic horn• Keyswitch start• Adjustable steer column• Rubber floor mat• High air intake• Integral tie downs• Operator restraint system	<ul style="list-style-type: none">• PSI 2.4L dual fuel engine - <i>coming soon</i>• Exclusive Foot Directional Control Pedal• High air intake with pre-cleaner• Accumulator• Keyless start (with auxiliary key switch)• Front and rear halogen or LED work lights• Anti-clog Plus radiator• Fire extinguisher• Load weight display - <i>coming soon</i>• Swing-out LPG tank bracket• Accutouch e-hydraulic controls - <i>coming soon</i>• Return-to-set-tilt (mechanical lever hydraulics) - <i>coming soon</i>• Rear drive handle with horn button• 10° forward/6° back tilt• Clamping hydraulic control with detent• 4-function hydraulic control valve• 84" overhead guard• 78" overhead guard• Cab kit with heater - <i>coming soon</i>• 12-volt power supply• Belly screen• Frame mounted external tie downs• Full-suspension seat – vinyl or cloth• Red, high-visibility, non-cinch seat belt• Polycarbonate overhead guard rain top• Integral sidershifter• Integral sidershifting fork positioner• Dual inch brake pedals• Dual side view mirrors• Audible alarm – reverse activated• Visible alarm – amber strobe• Visible alarm – blue spot light• Various light packages• Overhead exhaust• Pneumatic shaped solid tires• Non-marking pneumatic shaped solid tires• Wide tread• Tilt cylinder boots• Traction speed limit - <i>coming soon</i>• Telemetry (3 levels)<ul style="list-style-type: none">L1 - Wireless monitoring (cellular or Wifi)L2 - Wireless access (for use with operator swipe cards)L3 - Wireless verification (facilitates operator checklist functionality)



YALE MATERIALS HANDLING CORPORATION • P.O. Box 7367, Greenville, NC 27835-7367

www.yale.com Manufactured in our own ISO 9001 and 14001 Registered Facilities

Yale is a Registered Trademark and  is a Registered Copyright. ©Yale Materials Handling Corporation 2016. All Rights Reserved.

Truck performance may be affected by the condition of the vehicle, how it is equipped and the application. Consult your Yale® Industrial Truck Dealer if any of the information shown is critical to your application. Specifications are subject to change without notice. CERTIFICATION: Yale lift trucks meet the design and construction requirements of B56.1-1969, per OSHA Section 1910.178(a)(2), and also comply with the B56.1 revision in effect at time of manufacture. Certification of compliance with the applicable ANSI standards appears on the lift truck. The Yale® products included in this document may be covered by US patent 6,684,148 and other patents pending.