

FLETCHER®

Model J101-AD/E

Narrow Single Boom Drill Jumbo

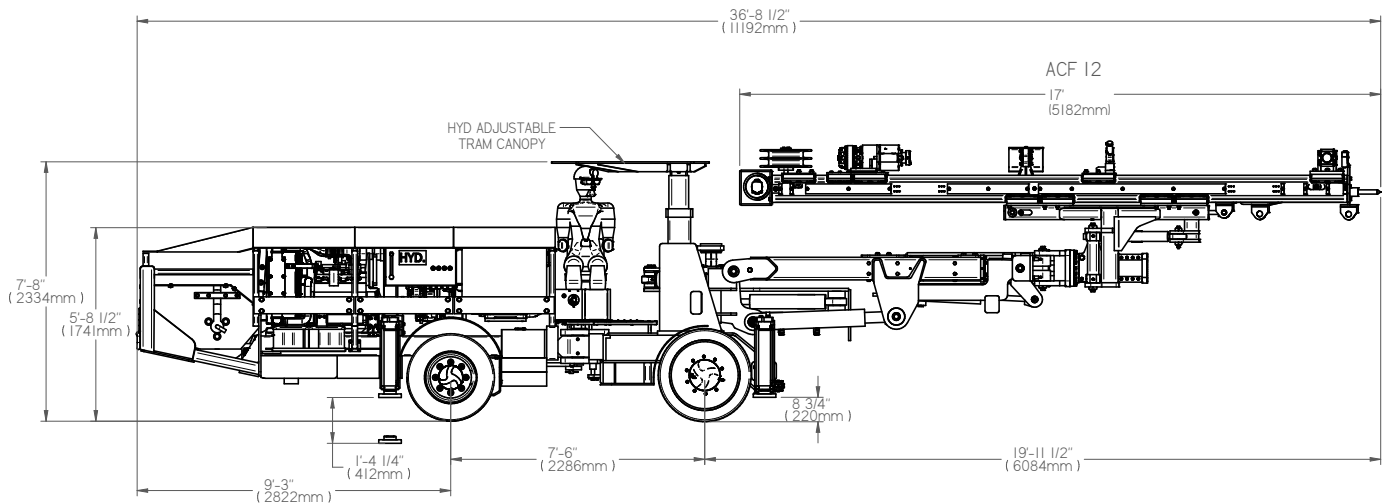

Fletcher model J101-AD/E is a diesel tram, electric drill jumbo for narrow vein mining applications in headings up to 22m². The rig is nimble in tight quarters with proportional control on tram and boom functions. Drilling efficiency is optimized with direct acting anti-jam circuit and a variety of rockdrills for various rock conditions.

Standard Equipment

- Four Wheel Drive
- Narrow Articulating Carrier
- High Pressure and Return Filters
- Fire Suppression System
- Front and Rear Stabilizers
- Adjustable Certified Operator Canopy
- Diesel Tram/Electric Drill
- Cable Reel with Spooler
- Water booster pressure pump

Specifications

Rock Drill	Fletcher HVL38
Feed	Cylinder & Cable in Aluminum Extruded Frame
Feed Lengths	up to 3m
Engine Power	100 Hp



Model J101-AD/E

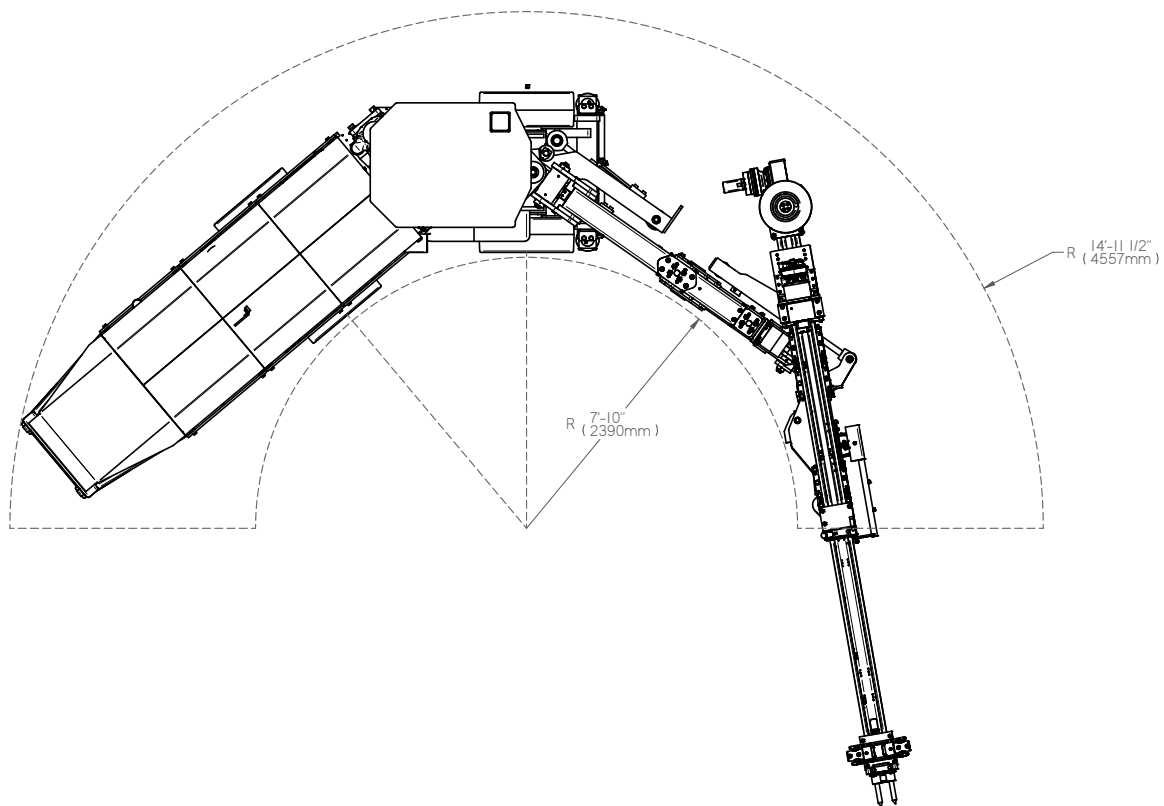

Specifications

Engine	Cummins 3.3, Tier III
Height	7' 8" (2.3 m)
Overall Width	4' 7½" (1.4 m)
Length – Overall	36' 8½" (11.18 m)
Weight (complete)	30,000 lbs (13,600 kg)
Underclearance	8 ¾" (223 mm) under stabilizers
Wheel base	7' 6" (2.29 m)
Turning Radius	14' 11½" outside (4.56 m) 7' 10" inside (2.38 m)
Min. Operating Height	8' (2.4 m)
Max. Operating Height	15' 5" (4.7 m)
Fuel Tank	40 Gallon (151.4 L)
Hydraulic Tank	40 Gallon (151.4 L)
Filters - Return	5 Micron
Filters - Pressure	5 Micron
Electrics	480 or 575 VAC
Tires	32-12.1 x 15 solid rubber

Highlighted Options

- Fletcher HV-32, Montabert HC110, or Montabert HC50 in lieu of Fletcher HVL38 rock drill
- 32-12.1 x 15 foam filled tires
- 24V electric fill pump for hydraulic oil
- Ansul checkfire automatic fire suppression system
- Wiggins no spill fueling system receiver for fuel tank
- Enclosed operator's cab
- Hydraulic lift operator's canopy
- Full function diesel/electric



Technology at Work Worldwide

J. H. Fletcher & Co.™
402 High St. P.O. Box 2187
Huntington, WV 25722-2187
sales@jhletcher.com
www.jhletcher.com
(304) 525-7811